



Description

The OMS 7 optical sensor combines non-contact, optical sensor technology with inertial measurement technology, enabling simultaneous measurement of a wide range of measured variables such as vehicle speeds, slip-, pitch and roll angles, accelerations and rotation rates.

The optical speed measurement is characterized by its long-term stability and high accuracy. The high bandwidths of angular rate and acceleration sensors enable the detection of the smallest, highly dynamic changes in movement.

The fusion of optical speed measurement and movement data from angular rate and acceleration sensors enables the measurement of all necessary parameters with unprecedented accuracy and dynamics. In this way, the OMS 7 helps our customers to successfully perform their measurement tasks in an efficient and simple way.

Features

- Proven spatial filter principle
- Precise, low-noise sideslip angle
- Integrated angular rate and acceleration sensors
- Sensor fusion
- Highest dynamics due to 1kHz update rate
- CAN output
- Simple parameterization via Ethernet
- Long-life IR-LED lighting
- POI conversion
- Easy handling
- Precise optics / optomechanics
- Protection against undervoltage by UPS

Applications

- Longitudinal and lateral dynamics tests
- Performance measurement tires and brakes
- Indoor testing
- Motorsport
- Land Survey
- ADAS testing
- Rail Applications
- Mobile machines
- Parking tests
- Industrial Applications

Technical data

Speed		
Measuring range	250/350/450	km/h
Nonlinearity	<±0.2	%FS
Angle		
Measuring range	±30	°
Measuring accuracy ±10°	<0.1	°
Measuring accuracy ±30°	<0.2	°
Optical resolution	≈0.6	mm
Working distance	300 ±150	mm
Angular velocities		
Measuring range	±500	°/s
In-run bias 1 σ	8	°/h
Accelerations		
Measuring range	±20	g
In-run bias 1 σ	13	μ g
Measurement frequency	1000	Hz
Signal delay	4.5	ms
Supply		
Voltage	10 ... 36	V
Power consumption (at 12 V)	<25	W
UPS	3	s
Environmental conditions		
Storage / Operation	-40 ... 85 / -25 ... 50	°C
Shock / Vibration (Sensor)	50 / 10	g
Dimensions		
Sensor (without connector)	95 x 65 x 40	mm
ECU	155 x 125 x 60	mm
Weight		
Sensor	450	g
ECU	900	g
Protection class		
Sensor (cable plugged)	IP68	
ECU	IP40	
Illumination	IR	
Wavelength	850	nm
CAN Interface	2.0B (isolated)	
Number of individual nodes	2	
Speed	125 / 250 / 500 / 1000	kBaud
Terminating resistor	switchable	
Ethernet Interface	Isolated	
Parameterization	Webinterface	
Measurement data	TCPIP (protocol on request)	
USB Interface	Protocol on request	
I/O Interface	Light barrier / brake switch / synchronization (Isolated)	



Ordering Code

OMS7 - □□□.□.□.□

Speed range [km/h]	250 350 450	
Orientation sensor	L: longitudinal T: transversal	
Orientation connector	H: horizontal V: vertical	
Length sensor cable [m]	5	

Scope of delivery

Sensor	
Sensor cable	MT0000062
Power cable	MT0000063
Transport case	MT0000207
Measuring tape	MT0000208

CAN cable	MT0000061
ETH cable	MT0000064
USB Stick	MT0000212
Set of screws	MT0000213
Screwdriver	MT0000214

Optional accessories

Towing Lug Mount T1	MT0000209
Side Mount S1	MT0000210
Side Mount M1	MT0000211

USB cable	MT0000065
I/O cable open end	MT0000066
I/O cable customized	on request

Customized cable on request

Drawings

Sensor

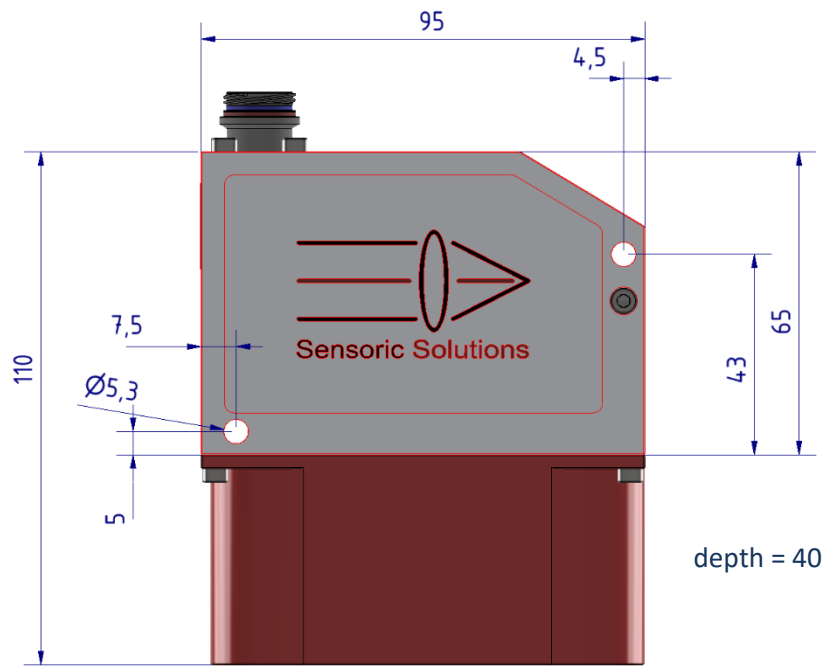

ECU

